

MORRIS MINOR OWNERS CLUB

NEWSLETTER

Dorset Branch



WANTED

**A CLOSE UP PHOTO
OF YOUR CAR TO
ENTER THE
DORSET BRANCH
'VIRTUAL RALLY'
& NEWSLETTER
COMPETITION
PRIZES TO WIN
(DETAILS PAGE 5)**

1948 < Morris Minor > 1971



OCTOBER 2020 Vol23, Issue 11
www.dorsetmmoc.co.uk

© Dorset Branch MMOC 2020

The MMOC Dorset Branch

was founded in 1980 by Graham Melly and chaired in the early days by Aubrey Batt. It is a Branch of the National Morris Minor Owners Club but has its own accounts and organisation (see Constitution for further details) **We meet on the first Wednesday of every month (7:30 for 8:00)** at the **Bournemouth Electric Club, Broadway Lane, BH8 0AA**. We have an active calendar of events throughout the year – particularly in the Summer months when we attend many rallies and other shows. The monthly Clubnight is an opportunity to meet the other enthusiasts and enjoy a presentation or other activity organised by the Committee.

Membership currently costs £12 per year—£15 for joint membership.

Dorset Branch MMOC Key Contacts

COMMITTEE MEMBERS

Chairman

John Jenkinson
01202 576690

Secretary

Laurie Blewer
01202 522673

Treasurer

Jacky Wood
01202 573494

Membership Sec.

Brian Ford
07502161535

Health & Safety (Events)

Andy Dibb
01590 674557

Welfare/Technical

Eddie Pateman
07940 518627

Spares Manager & Website Editor

Brian Wood
07411 116336

Newsletter Editor

Roger Kellow
drkellow@ymail.com
07845768120

The Dorset Branch Newsletter is published on the first Wednesday of the month and sent by post to paid-up members. It is also available for download from the Internet usually about 10 days before the clubnight.

NON COMMITTEE POSTS

Raffle

Chris Tilley

Coordinators

Margaret Pateman

Catering

Consultant

Sue Blewer

Insurance Advisor (to Dorset branch)

Dave Walker

COVER STORY

13 UXW

Mike Smith's Saloon

on show at

'Simply British' Classics

at Beaulieu

Sunday 20h Sept

(An example of the type of close up photo we are requesting for the DMMOC Virtual Rally and Newsletter Competition)

Details Page 5

Dorset Branch Newsletter

MORRIS MINOR OWNERS CLUB

OCT 2020 Volume 23 Issue 11



NEXT CLUBNIGHT

Postponed until further notice

In This Months Issue...

REGULARS	SPECIAL FEATURES
EDITORIAL P. 4 & EDITORS 'IN BOX - NEWS DESK' P.5	P.8/9 Eddie's 'Virtual ' Gardening Competition Winners
SECRETARY'S REPORT P.6	P.10 Update from our Correspondent
GREMLINS AT WORK SERIES P.7	P. 11 Where Was Your Minor Registered ?
CHAIRMANS REPORT P. 13	P.16/17 Dr Beeching, Saint or Sinner ? by Andy Gibb
VEHICLES FOR SALE - SPARE PARTS FOR SALE & WANTED P.14	P18/19 Grahams Series II project continues
THE 'BRIAN WOOD' REPORT P.15	P.20 The Nuffield Organisation
	P.22/23 Simply British at Beaulieu

Dorset Branch Members- It's Your Newsletter - It's Your Club !

The Editor encourages and welcomes any written contributions - particularly loaned (or emailed) photos please, of topical interest, from club members suitable for inclusion in the monthly club newsletter .

****Please submit , if possible ,any material or advertising matter, within 10 days prior to the next monthly club night date . (*Inclusion within the next available published newsletter is subject to space, as it approaches the next respective monthly publishing deadline. The Dorset Branch MMOC will accept no liability in respect of goods or services provided by advertisers : No recommendation is implied : Any views expressed or advice given within the newsletter is offered in good faith and no liability is accepted by the Dorset branch or the MMOC for any consequences arising from such material.***

Welcome to the October Newsletter — Following the last strange 6 months it appears the country is in for a 'challenging' winter and accepting that we are to recognise life with 'bubbles' of all changing shapes and sizes also evolving, changing of restrictions that will inevitably continue to effect, in various ways, every responsible classic car club, such the DMMOC.

There have understandably only been a few 'covid assured secure' socially distanced and professionally managed events recently. One of these the 'Simply British' Beaulieu event is reported on by 3 members who attended on P.22/23

It's High Time for a Branch Car Competition !! Combining the fact that the Dorset branch has not enjoyed that usual, popular, well attended Annual Branch Rally and also with Moggyfest not happening, The Dorset branch has decided to announce - **THE 2020 DMMOC**

VIRTUAL RALLY' with associated 40TH ANNIVERSARY NEWSLETTER COMPETITION

(the Dorset branch have pledged a budget total of prize vouchers to be won for 'at least' £200)
please see announcement next page.

One of the enjoyable and often fascinating aspects (besides the 'pride of ownership' of a classic car and the 'old car driving experience' it is the very unique history of any classic car that belongs to each individual branch member. Often the most basic research starting point will be where in the country your car was first registered. Usually an easy task if the car registration plate is the original one issued at first time of registration. Having obtained that basic information it can often prompt the owner to begin imagining the cars early life (Perhaps it survived severe winters in the far north of Scotland, Wales or the Yorkshire Dales perhaps if registered there, It may have lived a pleasant life in Sunny Devon or the typically English gentle setting of a Cotswolds village, perhaps it spent it's early life negotiating the windy and hilly roads of Cornwall.

Imagining the cars early surroundings often triggers that incentive in trying to discover information about the cars previous owner's - as an example I was able to establish my saloon was first owned by a lady who would probably have been described as a 'Lady of leisure' who lived in a very 'well healed' village near Rickmansworth, Hertfordshire. The car having been originally first registered in the neighbouring Middlesex. It was then sold on to a lady in another quaint village in hilly north Somerset. The third owner was, an English employee at Disneyland Paris who used it there when the site first opened in 1992. Hence the reason I kept finding French coins, maps, French labelled oil cans etc. It may explain the strange system of rear view mirrors arranged in order to reflect from the one only passenger side wing mirror fitted, obviously to assist with right hand driver position overtaking. Then there was the very odd wiring and coil—perhaps work of a French 'Mechanic' ("mecanicien de garage de village")

We particularly want your first registration date and details as it will be used in connection with some of the prize category awards The competition is open now for entries from all DMMOC members, winners to be announced later in December - It's so simple to enter.

Eddie's 'Virtual Gardening Competition'—the winners are featured on pages 8 & 9.

As a matter of interest, Eddie judged the winners just before going into Southampton General for his heart operation, I am sure every member join the committee in wishing him a very speedy recovery.

Graham Melly's 'continuing project' of his Series II saloon, the story resumes of a job starting up after 39 years of being stored in his garage! the car having been 'moth balled' just a year after Graham was the person responsible for starting the Dorset Branch 40 years ago! Also please note the photo caption request of Graham shown in full PPE !!

Dr Beeching is remembered from that era a lot of us have memories of, when cars and roads competed with an under invested and 'post war weary' British railway structure from the 60's to the 70's Thanks to **ANDY DIBB** for a very interesting article and insight on this character who was not a politician but simply employed to present a specific cost saving report for the government from industry.

Hope you are able to get out and about to simply keep enjoying your Minor **ROGER**





BRANCH MEMBES ATTEND 'SIMPLY BRITISH'

At least 10 Morris Minors joined many other British made classic cars with their owners and companions at the 'pre-booked event at Beaulieu on Sunday 20th Sept. One of a limited series of special covid secure 'Simply Classic' vehicle marque themed events hosted by Beaulieu— report from three members that attended and photos on pages 22 & 23

ANNOUNCING THE 40th ANNIVERSARY NEWSLETTER COMPETITION (VIRTUAL CAR RALLY) WE WANT A PHOTO OF YOUR CAR!

*** TOTAL PRIZE VALUE OF 'AT LEAST' £200 SPREAD ACROSS 4 PRIZES - INCLUDING VOUCHERS TO SPEND ON CLUB SPARES OF YOUR CHOICE**

IT'S FREE TO ENTER, ALL YOU NEED TO DO IS SEND IN :-

1. One close up photo of your car (Similar to this months front cover or any other angle 'close up' of your car)
2. It can be a Minor or 'other make' of classic that is owned by any paid up branch member, in all conditions, either running normally or can be an ongoing project (each 'one close up' photo from each member will be published)
3. The car's original number plate registration .
3. The year the car was first registered and where if known within the British Isles matching the 'area identifier' two letters (SEE PAGE 11 for 'area identifier' guide and information) If in doubt we can help with the original number plate 'area identifier' and just send in the photo anyway preferably by email please to the Editor



PLEASE, SEND IN THAT CLOSE UP PHOTO OF YOUR CAR NOW TO START OFF THE 'VIRTUAL RALLY' AND 40th ANNIVERSARY NEWSLETTER COMPETITION
***More Specific Details on Prizes in the Nov Newsletter.**

DRIVER LICENCE PHOTO CARD—AUTOMATIC RENEWAL

Don't Panic, the DVLA has clarified its guidance regarding Driver Licence Photocards that are due for renewal between 1st February and 31st December 2020 following extensive problems reported by drivers experiencing difficulty communicating their renewal requests. Due to no paper applications being processed during these exceptional times. There will be an 11 month Automatic extension of expired Driver Licence Photocards even though the online database check form will not show the 11 month extension However the DVLA state the police, insurance providers, car rental companies and others have all been told about the extension period. The DVLA also state the 11 month 'automatic renewal grace of extension' includes drivers over 70 and even includes drivers with a medical condition holding 'short period' driving licences.

Secretary's Report



Well, here we are in October and we should be looking back upon a very busy rally season celebrating 40 years of the Dorset Branch. We have so many regular events cancelled this year due to the dreaded Covid 19 and I really hope that next year we will be able to get back to some sense of normality.

Now, October should be our AGM of course but we are unable to hold this year we have had authorisation from the National MMOC to postpone it for up to 6 months. We have sadly had 2 members of the committee stand down this year. Andy Dibb, our Events and Health Safety Officer has been a much valued member of the committee team for the last few years and his organisational skill will be much missed – thank you Andy for everything you have done. John Jenkinson, our beloved Chairman, has decided to retire after 17 years in the role. We will miss John's firm hand over us at committee meetings as we can sometimes get a bit carried away! He has been a fantastic chairman and we will all miss him immensely. How does John Jenkinson for Club President sound to you all? These changes of course mean that new committee members are required. I have agreed to stand in as Acting Chairman until such time as an actual AGM can be held and Ian Chivers has agreed to be Acting Secretary in my place. This does leave a vacancy to fill Andy's shoes so if you are interested please let me know.

On August Bank Holiday Monday we were invited at the last minute to take our cars along to the SEB Club for their 999 Emergency Services Day. I put out the call via our Facebook page and managed to get about 14 cars along on the day. It was a very well organised event with a good display of vintage and classic Fire Engines and Police cars along with fabulous music all provided by the SEB Clubs resident jazz band. If life ever returns to normal I think it would be a super venue for a classic car show.

We have now been along to Classic Cars On The Farm a few times during the late summer/early autumn. Thank you to Ashley Miller and his team for a brilliant socially distanced event.

We had a good turnout of club cars at the recent Simply British Classics event at Beaulieu. 6 cars met up at Burley Cricket Club for the drive through the New Forest to The National Motor Museum. I presume I was asked to go in the lead as I was driving a Series II so I apologise if you were having to go quite fast but she seemed to be going extremely well that day but my speedo never registered more than 40mph – honestly!

It was with a sad heart and a tear in my eye that we said goodbye to Snowy, our Traveller last month. Unfortunately, needs must, as they say, and she wasn't being used very much having done no more than 50 miles all year! I have already filled the space in the garage but not with another car – I am finally building my O gauge train set which has been stored away for many years.

I think that's about all from me for this month, so until next time –

Happy Minorng, Laurie.



THE 'GREMLINS AT WORK' SERIES

(An imaginary mischievous sprite, regarded as responsible for an unexplained mechanical or electronic problem or fault, 'Gremlins' were popularised by Roald Dahl when he was a fighter pilot in the RAF during WW2)



A Carburettor 'Conundrum'

A most unusual fault has occurred here. The illustration shows an SU carburettor jet body removed for inspection. Clearly visible is the crack running halfway from top to bottom. The material is thin brass tube and must have simply suffered from what doctors refer to as an "Age - related problem." No physical damage can be inflicted to this area as it is contained inside another tube (the jet block) whilst in service.



It is interesting to note that the jet proper is simply an accurately drilled 'washer' which is crimped into the top of this tube. The crack has allowed the jet to be released from its rightful position thus rendering it inoperative. The car's owner, looking for the cause of constant flooding, stripped the carburettor and the 'jet' fell out unseen. The reassembled carburettor was refitted to the car and of course the flooding continued!

'At least 49 parts of the later series HS2 Carburettor

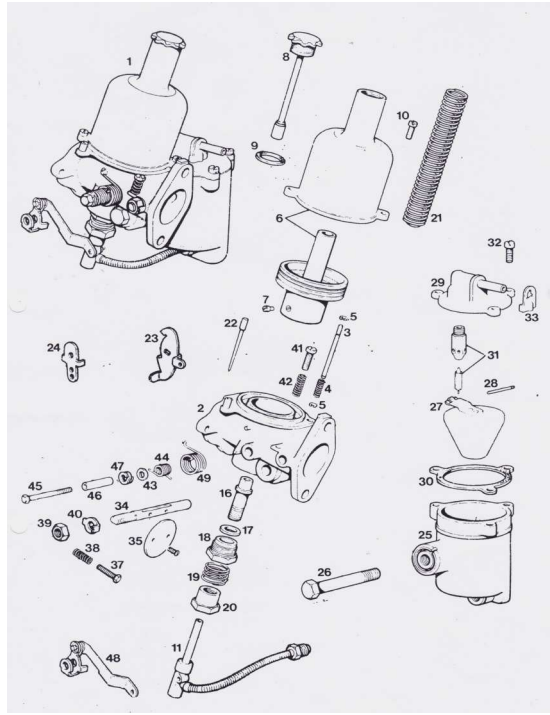

- Single carburettor — HS2 — for use with 1098cc engines No. 10V/189E/ H301 on 10V/190E/ H401 on
- 1 Carburettor assembly
 - 2 Body
 - 3 Pin — piston lifting
 - 4 Spring — pin
 - 5 Circlip — pin
 - 6 Chamber and piston assembly
 - 7 Screw — needle locking
 - 8 Cap and damper
 - 9 Washer — fibre
 - 10 Screw — chamber to body
 - 11 Jet assembly
 - 16 Bearing — jet
 - 17 Washer — jet bearing (brass)
 - 18 Screw — jet locking
 - 19 Spring — jet locking
 - 20 Screw — jet adjusting
 - 21 Spring — piston — red
 - 22 Needle — jet — rich (HC)
 - 22 Needle — jet — standard (AN)
 - 23 Needle — jet — weak (EB)
 - 24 Lever — throttle return
 - 24 Lever — cam
 - 25 Chamber — float
 - 26 Bolt — float chamber fixing
 - 27 Float
 - 28 Pin — hinge
 - 29 Lid — float chamber
 - 30 Washer — lid
 - 31 Needle and seat
 - 32 Screw — lid
 - 33 Plate — baffle
 - 34 Spindle — throttle
 - 35 Disc — throttle
 - 36 Screw — disc
 - 37 Screw — stop
 - 38 Spring — screw
 - 39 Nut — spindle
 - 40 Washer — tab
 - 41 Screw — throttle stop
 - 42 Spring — screw
 - 43 Washer — cam lever
 - 44 Spring — cam lever
 - 45 Bolt — pivot
 - 46 Tube — pivot bolt
 - 47 Washer — spring
 - 48 Lever and link pick-up
 - 49 Spring — pick-up lever

EDDIE'S 'VIRTUAL' GARDENING COMPETITION



**AND THE
WINNERS ARE
(All will receive
DMMOC rosettes
in the post)**

Class 13 . Peppers - Dave Saggs



Class 12. Marrow - Patricia & Geoff Newbury



Class 11. Onions - Roy Gale



Class 10. Cucumber—Marilyn Kellow



Class 9. Med Tomatoes—Pauline Ford

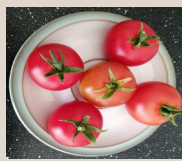

Class 8. Cherry Tomatoes - Dave Saggs



Class 7. Potatoes—Pauline Ford



Class 6. Runner Beans—Olivia Akam



Class 5. Potted Plant—Helena Carr



Class 3. Fuschia - Sue Gale



Class 2. Sweet Peas—Roger Kellow



**(NO ENTRIES RECEIVED FOR CLASSES 1. or 4.)
THANK YOU TO MEMBERS WHO ENTERED PHOTOS**



LETTER TO THE EDITOR ... It's great to hear from Roger Blakeley and things he has been up to lately, a long term Dorset branch member and regular contributor to the newsletter. Many club members including myself do miss seeing him locally as he now resides in the East of England .

Dear Editor

Our secretary asks what the members have been doing since 'The Plague' altered everyone's routine. For me the biggest change has been to use my car more often. Being a bus pass holder and a notorious penny-pincher I firmly believe in using free transport whenever possible. Since it became advisable to stay far away from others I have given up my twice-weekly shopping trips and my two-bus journey to visit the other half of my 'social bubble'. (Can there be half a bubble?) Instead the car is used for fortnightly journeys which combine both purposes and put around a hundred and fifty miles a month on the clock. Apart from a grease-round and fitting a new tyre from my stock of secondhand crossplies I haven't needed to do any serious car maintenance for three years, although I suspect that the nine year old battery may be about to face its last winter.

My BSA motorcycle had its last short run in March, since when it has been hibernating under a duvet (13.5 tog) in my shed. All the planned outings for that vehicle were cancelled at a stroke; apart from a monthly trickle charge it will be undisturbed until next Spring.



about a stroke; apart from a monthly trickle charge it will be undisturbed until next Spring.

About 25 years ago I acquired the scruffy chassis and cab of a 1950s Guy 6-ton lorry. Recently I have bought a new set of tyres, built a platform body and have almost finished a complete repaint. This job has taken much longer than I expected because I scrapped the first body I made, then dithered over the colour, trying maroon then green before settling on red. Thankfully it's a Dinky Toy, I dread to think how long it would have taken me to restore a real one.

For the first time in 20 years I'm growing runner beans simply because I was given some seeds. They have been quite productive and I expect to grow more next year. An old friend persuaded me to build him two pairs of motorcycle wheels and I've rescued a couple of bicycles from a garden and after refurbishment have moved them on to more appreciative owners. Internet sessions at my local library have been drastically cut but I've acquired a secondhand laptop and have managed to bash out a couple of articles for the newsletter. Compared to working in the library it takes twice as long to write these at home because I keep taking tea breaks. A sunny day may see me out on a cycle ride, nothing adventurous, usually around fifteen miles in order to comply with the Kommissariat's instruction to exercise regularly!



Many things haven't really changed that much but the way we go about them has; won't it be nice when we get back to normal? **ROGER BLAKELEY**

WHERE WAS YOUR MINOR FIRST REGISTERED ?

In the vast majority of cases the 'Area Identifier' (two letter code) should confirm this as below . Please send your full number plate registration and the area that you car was first registered (if known), otherwise we can help with your area letters code. Also tog your Minor model and year when sending in your car 'close up' car photo to the

40th ANNIVERSARY NEWSLETTER COMPETION (Details on Page 5)

AB 1234 1 OR 2 LETTER PLATES ONE OR TWO LETTERS FOLLOWED BY ONE TO FOUR NUMBERS OR REVERSE These plates are rare and are normally only seen on newer vehicles as cherished or personalised numbers. However, some still exist and were originally issued to vehicles first registered between 1903 and the mid 1930's. The reverse (where the one or two letters follow the numbers) are very rare - only a few of these were issued in the 1950's / 60's when three letter plate combinations ran out. The one or two letters, in the above example AB, make up the 'area identifier' and indicate where the vehicle was first registered

ABC 123 3 LETTER PLATES BEFORE 1963 THREE LETTERS, ONE TO THREE NUMBERS OR REVERSE On cars first registered before 1963 (or 1965 in some cases), number plates look like this. The plates usually carry the three letters before the numbers between 1 and 999, but some are reversed with the numbers preceding the letters. In the group of three letters, the second and third letter, in the above example BC, make up the 'area identifier' and indicate where the vehicle was first registered.

ABC 123A PLATES 1963 - 1983 (YEAR SUFFIX)THREE LETTERS, ONE TO THREE NUMBERS, ONE LETTER This is the format of registration used on vehicles first registered between 1963 and 1983.The second two letters, in the above example BC, are the 'area identifier' and indicate where the vehicle was first registered. Area identifiers for vehicles first registered from 1 September 2001 are different to those used with this system. The last letter, in the above example A, is the 'age identifier' or 'year letter' and shows the date when the vehicle was first registered- in this case during 1963. Year letters were not compulsory until 1965, so a vehicle may have been registered during 1963 and1964 without a year letter. The first letter and numbers, in the above example A__ 123 are the individual element which give the vehicle it's unique identity.



Specialist body repairs and paintwork: Free estimates. All insurance repairs undertaken. Collection and

ACCIDENT REPAIR CENTRE.

Low Bake Oven & Body Jig

Kevin Owen

**UNIT 5, BROOK PARK, 27 BROOK ROAD, WIMBORNE, DORSET, BH21 2BH. Telephone (01202) 887727
www.bodycare-arc.co.uk**



MRF CLASSICS MOBILE MECHANIC



SERVICING & REPAIRS

** Specialising in Classic Cars **

British Leyland trained:

45 years in the motor trade

No obligation quotes & consultations:

**CONTACT MARTIN: 07521 643751
mrfclassics@talktalk.net**

New Morris Minor Spares are available through the club. The current list is posted on the website under the 'New Spares' tab. *We can also order other items for you—usually saving the postage cost.*
Brian. 07411 116336

ORIGINAL CLASSIC PLATES FOR YOUR MORRIS MINOR

Front Plate



Rear Plate



"It's nice to know that someone does a plate that fits the back of a Morris Minor. It's a lovely plate and the service was very prompt. I'm very pleased with the finished result"

John Jenkinson, Chairman
Morris Minor Owners Club, Dorset Branch

Our Morris Minor plates are specially designed with radius corners to fit the rear aperture of a Morris Minor. All our embossed aluminium plates are handmade using traditional methods, stoving enamels and decades of experience.



0114 273 1151
www.jepsonclassicplates.com
Jepson Classic Plates. 44 East Bank Road, Sheffield, S2 3QN

Chairmans Report



Hello to all the Branch Members and welcome to the branch news bulletin no.6 of the Corona Lockdown of 2020. We had another committee meeting on the computer this month and we seem to get better each month now we know what to do!

It was good to hear that Eddie now has a date for his heart operation at Southampton Hospital. We will be thinking of you Eddie.

Charlie and myself are still doing Wimborne Market on a Saturday morning with a stall selling my radios and record players and other bits and pieces. Also passed his CBT test on his scooter -first time. Well done!

The time has come for all the businesses to renew their adverts in the Branch Magazine so I would like to thank all the advertisers for their support over the past difficult year. Brian Ford, the membership secretary said that at the Committee meeting that the Branch renewals are coming in well and so far there are just over 90 renewals which is good news.

Thanks to all the members who have renewed their membership. I heard that Beaulieu Simply British Classics went well - with some of the Branch Members with their Minors and other makes. You all had a good day out. I bet it was nice to go out for a day's run in the classic.

As you know I am standing down as Chairman after 17 years - so I would like to thank my Committee, caterers, raffle coordinators and regalia sellers for all their hard work over the years and also the Members for their support. It was good to hear that Laurie Blewer will be Acting Chairman for the time being pending the AGM. Also glad to hear that Ian Chivers has volunteered to stand for the committee as Acting Secretary to replace Laurie. It was sad to hear that Andy Dibb had decided to stand down from the Committee so I would like to thank Andy for all his support and hard work for the Branch.

So finally, I would just say that I will still be a Branch Member and hope to meet with you all again in the not too distant future.

Best Wishes and Happy Minoring, John.

VEHICLES, SPARES, PARTS FOR SALE & WANTED

DORSE BRANCH CLUB SPARES ARE AVAILABLE TO ORDER AS USUAL FROM BRIAN Please telephone Brian on **07411 116336** to place your order. If it is in stock you can call in to collect or it can be posted to you. If you have email, the invoice can be sent to you and it would be appreciated if you could either bring the correct cash, pay by cheque (by agreement) or use bank transfer (BACS) which is preferred. We usually order parts in approximately twice per month, or individual items can be obtained if urgent. (It's as close as we can get to 'Click and Collect'!)

WIPER MOTORS

Brian has unearthed a stash of these which he is going to try and refurbish. These should be available soon. Please phone for details, availability and price.

07411 116336

4 ITEMS FOR SALE (Surplus to Requirements)

**Morris Minor Workshop Manual £2.50*
**Desmo Wing Mirror Head Only (in as new condition) £4.00*
**One 1098cc 8" Brake Drum (Excellent Condition) £2.50*
**Brand New Minor 1000 Petrol Cap (Still in Packet) Cost £14.00 Bargain at £7.00*
Tel 01202 697044 : Branch member ROY GALE

SOME of the club second hand spares available - call 07411 116336

Air filters
 Ash trays (late)
 Axle stands (folding)
 Bonnet hinges
 Extending Bonnet stay (plated)
 Bottom hose
 Brake backplates (8")
 Bump stop (RH)
 Marina type column ind switch
 Distributors
 Chrome door handles (various)
 Front Grille outer panel
 Gearbox floor cover

Half shafts (single or pairs)
 Jack (standard Minor)
 Starting handle
 Front side/indicator units (late)
 Marina pedal box
 Books/Manuals (various)
 Quarterlights (painted/stainless)
 Rocker box covers
 Sliding boot stay
 Speedo heads
 King pins/good trunnions
 Top hose

A full list of S/H spares can be found on the website at :- www.dorsetmmoc.co.uk (go to S/H Spares page and download the list)
Or call 07411 116336

Refurbished Stock

803 gearbox £325
SU Fuel pumps £60
Starter Motors* £20

10% discount applies to most new spares

(* Painted and tested only)
 Available Through Club Spares
07411 116336



KINSON TYRE SERVICE

01202 573698 / 576653

1469 Wimborne Road Northborne Bournemouth BH10 7BQ



Call any member of the team on 01202 894080 to get exclusive MMOC discount across a range of vehicle parts and accessories!

We also offer cycle parts and accessories!

THE 'BRIAN WOOD' REPORT



The 'Simply British Classics' day at Beaulieu on 20 September went ahead as planned and it was a lovely day – sunny but not too hot. It gave us a chance to stretch the 'new' Convertible's legs – as it was the furthest we have been in it so far. It is now pushing 500 miles on the speedo. It performed very well, but we noticed how bumpy the roads in the New Forest are. Perhaps they have got worse since last year or the telescopic shock absorbers are too unforgiving. Anyway, it has the unfortunate effect of popping the bonnet open on the worst potholes – a problem which I thought I had already cured. I fitted a little dash cam in front of the mirror and it responds to inertial shocks – believing that we have crashed – by bleeping and preserving the footage. I have yet to watch it back to see if the potholes were recorded. Whilst there, one meeting was with David Grice who is a member of the Hants Branch (HAMMOC). He was keen to show me some of the little modifications he has carried out to his Traveller and asked me if I could share them with our membership. I guess there are lots of little improvements we can make to the cars to make them just a little easier to live with. The first was a simple modification to the rest inside the door that the drop glass rests upon. David has put a little foam 15mm plumber's pipe insulation over it to cushion the window bottom channel. This is closed-cell foam so it doesn't hold moisture. Next up is a simple



but semi-permanent way to mark the plug leads so they go back on to the correct plug. Some of us use Tippex to mark them, but that doesn't last very long. David's idea is to use small cable ties; 1- for

no.1, 2 for no. 2 etc. This makes quite a neat solution to this problem. He seemed to have trouble with the reflectors on the Traveller rear posts so he came up with the idea of fixing them securely with mirror screws drilled in through the centre. They have little chrome plated finishing domes which cover the screws. Whilst Travellers never had an 'official' cover for the spare wheel opening – many of us have made their own. David had made such a cover, but he has fitted a magnetic strip along the top edge which clings to the metal profile on the rear floor area. He has also put a couple of reflectors on the cover for extra visibility if the doors are



open at night. Thanks once again to David for his set of simple mods that he shared with me whilst at the Simply British Beaulieu event, hopefully some of us can make use of his ideas.

BRIAN

**OUR RESIDENT STEAM RAILWAY OFFICIONADO AND ENTHUSIAST ANDY DIBB
TRANSPORTS US BACK TO THE 1960's DIMINISHING 'GOLDEN DAYS' OF STEAM '
EXPLORING , THE THEN , TWO SUCCESSIVE GOVERNMENTS 'JUGGLING ACT '
CONCERNING BRITAIN'S RAILWAYS VERSES A ROAD 'MODERNISATION' SYSTEM .**

DOCTOR BEECHING SAINT OR SINNER?

Those of us of a certain age will remember Dr Beeching as the axeman of our railways who closed our beloved small branch lines and quite a few main lines and stations. Who caused social hardship and created severe job losses not just in the railway industry?

I would like you to look at him in another light if you would indulge me for a while.

Leading up to Beeching being employed by the government there were losses on the railways of £100 million per annum. Private car ownership had rocketed and major road building had increased. Lorry freight had increased in no small part due to the privatisation of British Road Services. Railway lines were already being closed and many more were named for closure due to low passenger and freight numbers.

Dr Richard Beeching was employed into this climate by the Tory Macmillan government in 1961 to be The

Chairman of British Railways. The Government Minister for Transport was Ernest Marple's who's firm was responsible for building a lot of our major roads including the M1. In fairness to him he assured The House that he had relinquished all dealings with the company.

Dr Beeching was a senior accountant industrialist from ICI and was seconded to the government until his contract was over and then would return to his employment at ICI. His salary was £24,000 (£37,000 today) which was £10,000 more than Prime Minister Macmillan.

His remit was to reduce the £100 million losses only. The social hardship and employment losses were the government's responsibility. He had to prove which lines were not paying their way and recom-

mend to government their closure.

Government had to approve closure after studying the effect on people's lives. There were already many lines recommended for closure before he took office and many more after, both of which he gets the blame for.

After he studied where the losses were greatest, he published the Reshaping of British Railways 27th March 1963. Reshaping not total closure! This named the lines under threat however some did survive. Towards the end of Beeching's time the Labour party were elected under Harold Wilson with

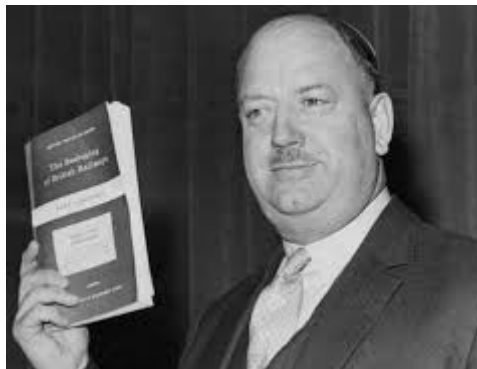

I would conclude that Beeching seems to be used as a scape goat for successive governments albeit a well-paid one. Maybe they should have called them the Marple's/Castle cuts!!! His reshaping of our railways was a way of making the system more streamlined concentrating on the mainline routes.

What is not commonly publicised is his success in the rail freight sector. He introduced container traffic, large bulk carrying of chemicals, ore, gypsum and coal. Merry go round trains from coal mine to power station non stop all day long. All used today bar the coal trains. Container trains run all day long from our ports of Southampton, Felixstowe and Harwich to name a few, where would our country be without them. We now have a third less track mileage but have the highest passenger numbers since the 1920s!!! Saint or Sinner?

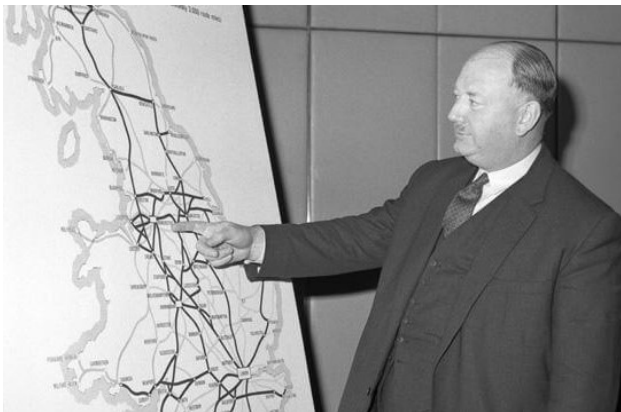

My Personal View

In the early sixties we could not have imagined what our world would be like today. Our love of car ownership in those and proceeding years played a large part in demise of unused railways. With hindsight we could have kept a lot of the lines open and they may have been used a lot. But the cost of that would be unacceptable at the time even to a Labour government.

Maybe we should have taken a leaf out of the French book when they needed to cut their railways costs. They shut their lines and mothballed them for 15 years. If anyone wanted to reopen or use them on the odd occasion for say transporting wine, machinery they would use it. After 15 years if there was no interest, they removed the track and equipment however the track bed was left along with bridges to be reused if necessary, not built on. They are now used for walking, cycling and even abseiling on some of the viaducts!

If this approach was used then one of my favourite lines The Great Central Railway that ran from the industrial heart of the country through the centre to London and it would have saved Billions now instead of the HS2 project. When it was built in 1899 it was fairly level, double track main line, bridges no road crossings and was built to the international loading gauge with a plan to tunnel underneath the channel to France.

Hope it helps redress your understanding of Beeching and maybe you will think of him in a different way.

ANDY DIBB

Local railway closures

Bournemouth West -Bath 3/1966 (Somerset & Dorset Railway)

Bournemouth West – Brockenhurst 5/1964 (Castleman's Corkscrew)

Axminster- Lyme Regis 1965.

Maiden Newton- Bridport 5/1975 (on Beeching's original list)

Wareham – Swanage 1/1972.

Research taken from , Beeching The Inside Track. Heritage Railway Publishers



**GRAHAM MELLY'S SERIES II MINOR PROJECT
AFTER IT'S 39 YEAR 'LOCK DOWN HIBERNATION'
(The Story Continues !)**

PART 3 'All Things GREY and Wonderful'

We resume Graham's story with the car shell being returned from the sprayers and clothed in a that strange shade of red due to the base upper body coating of 'Red Oxide' - Any caption suitable for the photo of Graham in his protection kit (opposite page) please, send in to Editor.



With the welding of all the floor panels completed by Nigel Seymour (below right) - The 4 floor panels that I cut and drilled so that they could be MIG welded are Hadrian make panels manufactured in GB. I have some Shri Lanka panels to go into the lower outside boot area and the lower inside boot lid. These hand made panels seem to have a better profile to the British equivalent panels. So far the floors are all done. I took the panels back to shiny bare metal before protecting with rich zinc metal primer. For the majority of the underside I used one called Zinga but there is also Galvafruid, both equally good at galvanic cathodic plating on the metal surface, and hopefully will last a long time before the dreaded metal moth attacks the body again. I have also lost count of how many rattle cans of Plastikote zinc primer as a finishing coat. Wickes or the Range sell these cans.



I have ground down the MIG welds flat and used Soudal light grey seam sealant on the edges of the panels to stop water ingress. This is a polyester seam sealant and it comes in 3 colours black white and grey. So more primer and now the final stretch with light grey stone chip spray over the wheel arches and underside. This is a resin and rubber compound that in theory should stop stones damaging the metal structure. Finally I will spray the top coat in the gloss body colour.



This instalment is titled " All Things Grey and Wonderful" as the primer, seam sealant, stone chip, and final gloss colour are all grey. My hair is grey these days and my name is Gra!!

The draw backs to all this work is that my pristine garage that I covered in old sheets and lots of large sections of cardboard to protect the shelving and floor are all coated with a dark grey film of dust from the cutting grinding drilling and sanding work. So eventually I will have a jolly good deep clean. **GRAHAM**

Please send a caption for this photo to the Editor >



Watch out for Graham's next instalment, updating us on the progress ED.)

HISTORY IN A NUTSHELL - THE NUFFIELD ORGANIZATION FROM FORMATION IN 1938 TO THE BRITISH LEYLAND MOTOR CORPORATION IN 1968

Nuffield Organization was the unincorporated umbrella-name or promotional name used for the charitable and commercial interests of owner and donor, **William Morris, 1st Viscount Nuffield.** (Right) The name was assumed following Nuffield's gift made to form his **Nuffield Foundation** in 1943, it linked his business interests to his existing very generous philanthropy. The same enterprises had previously been referred to as the



Old Trading Card 'Captains of Industry' Series

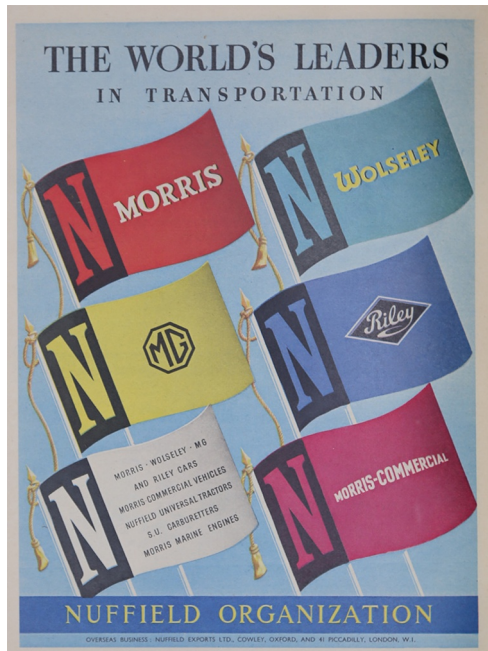

Morris Organizations and at first described itself as The Nuffield Organization, 'A Cornerstone of Britain's Industrial Structure'.

In 1938 The company was formed, Its main components were: Morris Motors Ltd— Wolseley Motors Ltd - M. G. Car Co Ltd - Riley (Coventry) Ltd - Morris Commercial Cars Ltd - Morris Industries Exports Ltd, S. U. Carburetter Co Ltd - Mechanizations and Aero Ltd. Lord Nuffield had purchased the bankrupt Riley (Coventry) and Autovia companies from the Riley family and quickly sold them to his own Morris Motor Company. With the addition of Wolseley later that year, the combined enterprise became known as the **Nuffield Organization.**

1939 and WWII: The Nuffield Organization was engaged in military production. Among their activities was production of the Liberty L-12 engine for use in British tanks of the period. One of their subsidiaries was given the opportunity to take part in production of the Covenanter tank then being designed but opted to develop their own version of the design which became the Crusader tank. They followed this with the Cavalier tank which used the Liberty engine as well. The tank was built but the power of the Liberty was limited and, with the increase in tank weight, the Cavalier was not used in combat. The last tank the Liberty engine was produced for was the Centaur tank, effectively an underpowered Cromwell. Commercial vehicles in the Morris range were produced for military use - such as the Morris C8.

1945 post war Automobile production of Morris, Wolseley and Riley marques restarted ,
1948 Nuffield started on tractor production with the Nuffield Universal.
1952 The Nuffield Organization merged with Austin to form the **British Motor Corporation.**
1966 British Motor Corporation merged with Jaguar to become **British Motor Holdings.**
1968 British Motor Holdings, still struggling, merged with the prosperous Leyland Motor Corporation to form the **British Leyland Motor Corporation.**



ON THE MINOR MISCELLANEOUS'

I'm entering it anyway into the Dorset Branch Virtual Rally competition !

I might win a voucher to spend on club spares to help finish the darned thing for the 'missus ere', who's also helping to try getting her Minor ready for finally driving out in it next spring !

Little Canford Garage Ltd.

**BOSCH SERVICING
CENTRE**

- *Servicing (classic and modern) *98 Wimborne Road West, Wimborne,*
 - *MOT's (inc. Class IV & VII) *Wimborne,*
 - *Car Repairs *Dorset, BH21 2DS,*
 - *Car Diagnostics *littlecanford@yahoo.co.uk*
- (discount on MOT's for Club Members)

Tel: 01202 883243 or 01202 886980

We specialise in all aspects of car repairs (ask for Colin)

TRAVEL LINK UK

AIRPORTS, DOCKS & DISTANCE **01202 300339**
www.travellinkuk.net 4, 5, 6, 7 & 8
travellinkuk@btopenworld.com SEATER VEHICLES

Old Autos

Old, Interesting and Classic Cars in any condition

BOUGHT AND SOLD

Paul 07890 096907, Ken 07814 385781
old_auto@yahoo.co.uk

Open Friday and Saturday or by appointment
 Southfields Farm, Church Ln, W.Parley, BH22 8TR

TOP MARK WINDSCREENS

CAR & COMMERCIAL GLAZING
 CLASSIC AND MODERN VEHICLES

Call today for a FREE Quotation **07971 956297 01202 534191**
www.topmarkwindscreens.co.uk
 email: info@topmarkwindscreens.co.uk

WINDSCREENS✓, REAR SCREENS✓, GLASS REPAIRS✓, SCRATCHES✓, BODY GLASS✓, MARINE✓

Bear Plumbing & Heating



Benn Brock

*bennbrock72@gmail.com
 07864860203*

FPCS

FAIR PRICE CLEARANCE SERVICES

COMMERCIAL/HOUSEHOLD WASTE COLLECTIONS
 HOUSE/GARAGE CLEARANCE, VEHICLE RECOVERY

CONTACT: KARL: 07711 770172 or STEWART: 07950 114960

Or email: infofpcs@aol.com

TIM LANG

CLASSICS

RESTORATION CENTRE

FOR ALL YOUR GARAGE WORK SERVICES AND RESTORATION/RENOVATION PROJECTS. HIGHLY REGARDED BY MMOC MEMBERS. FOR AN HONEST AND RELIABLE

SERVICE PLEASE CONTACT US ON:

01823 461861

enquiries@minormagic.co.uk

www.carrestorationuk.co.uk

'SIMPLY BRITISH 'CLASSICS ' EVENT BEAULIEU



Three of our branch committee members attended the event , along with some branch members who had also decided to confidently pre-booked this special 'covid compliant' assured event. As we hear within the three reports the event also allowed access to visit all the other usual attractions including finding a quite a few new ones that Beaulieu have obviously substantially invested in looking to an optimistic future .HERE's HOPING THE DORSET BRANCH MOGGYFEST WILL RETURN AGAIN TO BEAULIEU IN 2021 !



BRIAN WOOD - The Event was very well managed and whilst there were a lot of participants – they were all well spaced out in the Beaulieu grounds. It looked like they allocated the normal area of a single trade stand to each car, which meant a generous spacing of vehicles. It didn't appear to be crowded with lots of people either – which is normally the case there – as it was pre-booked only. I had the opportunity to meet up (masked, of course) with old friends and catch up on their news and Morris Minor tales. We also had a look round the Museum – which has a strict one-way system – and noticed quite a few new exhibits since we were last there. All in all, it was a great day at Beaulieu . We had been looking forward to going for many weeks and in a year when there are only a handful of events to at-





Laurie Blewer - Six cars met up at the Burley Cricket Club at 9:30 on Sunday 20th September. Members there were – us, Nev and Lyn, Brian and Jacky, Ian, Tracy and Ethan, Mike and Enid and John and Manina. I then led the way across the Forest to the National Motor Museum where we joined about 200 other fabulous vehicles for a brilliant day out. The Series II seemed to be running exceptionally well that morning and I apologise if I was going a bit fast! Once there we met up with the HAMMOC contingent of Tim Rouse, Giles Vodicka and David Grice, all of whom are also Dorset Branch members along with Arthur and Jill who were there in the Austin and Alan and Lyn Hammerton in the Wolseley 1500. Quite a few others MMOC members were also there.

The staff and management team at Beaulieu have got everything set up very well and we really felt very safe all day. We didn't see much of Louise and Ethan as they spent most of the day in "Little Beaulieu" – the brand new adventure play ground which can only be described as fantastic. The new display in the museum – Motoring in Miniature – is brilliant and I recommend you visit soon to see it.

Sadly, before we knew it the day was over and we had to go home. Hopefully the team at Beaulieu will hold the event again next year under better circumstances as a few trade stand would have been a very welcome distraction.



Brian Ford - I decided that I wanted at least to attend this one particular event at Beaulieu but I did not take my Rover as it is being worked on during Covid. The event at Beaulieu was very well organised, cars were well spaced in their rows and all the rows were well apart. they took up two large fields. It was a big but well organised event, I am glad that I went. It was strange inso much as it was eerily quite, but everyone was eager to talk about their vehicles and I did not feel unsafe at anytime over the whole duration of being there. Unfortunately I didn't take any photos myself but other branch members made up for this by taking more than enough !



Precision Clutch Components

Sales: Simon Davis, Shaftesbury Road, Henstridge, Templecombe, Somerset, BA8 0PP

SAMPLE PRICES: Rebuilt/
Exchange clutches for Minor
£65 (948cc) £65 (1098cc)

Tel: 01963 362484 Fax: 01963 364146
E: precisionclutch@aol.com
www.precisionclutch.co.uk

01425 404142 Office
07802 200935 mobile



steve@castle-marquees.com
www.castle-marquees.com

**UP AND OVER GARAGE DOORS
AND SHUTTERS LTD**



Garage Door Repairs, New & Used Garage Doors
Supplied & Fitted in Dorset, Hants, Wilts & Surrey
Call Frank on 07949 913373 or 01202 523334
www.upandovergaragedoorsandshutters.co.uk

ESM MORRIS MINORS



ESM - Partners with & distributors for
Morris Minor Centre (Bath) Ltd
Est 1982
www.morrisminors.com

Old Factory Buildings, Battenhurst Road, Stonegate, Wadhurst
E.Sussex, TN5 7DU. Parts: 01580 200203

BRANCH REBATE SCHEME

You may be aware that the branch receives a financial rebate according to the numbers of national MMOC members who attend the monthly clubnights. We therefore need to update our records so that we can take advantage of this scheme. Please would you advise the Membership Secretary of your **MMOC membership number** and renewal date and make sure that you sign the attendance sheet at the club-nights. Thanks.

CHARLES WARE'S MORRIS MINOR CENTRE

www.morrisminor.org.uk



RESTORATION

MOT, Repairs,
Service, Welding,
Body, Paint & Trim

SPARE PARTS

Comprehensive
range for all makes
and models

Sales: (0117) 3003 754 Parts: (0117) 3003 753
20 Clothier Road, Bristol, BS4 5PS
morris.minor@charleswaresmmc.co.uk



**Don't Forget to enter a close up-
photo of your car to enter the
'Virtual Rally' and Competition .
Open now for entries from all DMMOC
members—now until December
(Send in to The Editor Please all photos
all will appear in the next newsletters)**



Printed by: **Adding Value Solutions Limited**

2 Friars Workshop, The Friars, Jedburgh, Roxburghshire, TD8 6BN

M : 07768 653017 T : 0870 360 7000 F : 0870 360 7001

E : stephen@addingvaluesolutions.co.uk - W : www.addingvaluesolutions.co.uk