

ESM MORRIS MINORS



ESM - Partners with & distributors for
Morris Minor Centre (Bath) Ltd
Est 1982

www.morrisminors.com

Old Factory Buildings, Battenhurst Road, Stonegate, Wadhurst
E.Sussex, TN15 7DU. Parts: 01580 200203

TRAVEL LINK UK

AIRPORTS, DOCKS & DISTANCE

01202 300339

www.travellinkuk.net

4, 5, 6, 7 & 8

travellinkuk@btopenworld.com

SEATER VEHICLES

MOTABITZ PLUS CYCLES & LEISURE

Call any member of the team on 01202 894080
to get exclusive MMOC discount across a range of
vehicle parts and accessories!

We also offer cycle parts and accessories!

KINSON TYRE SERVICE



01202 573698 / 576653

1469 Wimborne Road Northborne Bournemouth BH10 7BQ

FPCS

FAIR PRICE CLEARANCE SERVICES

COMMERCIAL/HOUSEHOLD WASTE COLLECTIONS

HOUSE/GARAGE CLEARANCE, VEHICLE RECOVERY

CONTACT: STEWART on :07950 114960

or email: infofpcs@aol.com

UP AND OVER GARAGE DOORS AND SHUTTERS LTD



Garage Door Repairs, New & Used Garage Doors
Supplied & Fitted in Dorset, Hants, Wilts & Surrey

Call Frank on 07949 913373 or 01202 523334

www.upandovergaragedoorsandshutters.co.uk



Precision Clutch Components

SAMPLE PRICES: Rebuilt/
Exchange clutches for Minor
£65 (948cc) £65 (1098cc)

Sales: Simon Davis, Shaftesbury Road,
Henstridge, Templecombe, Somerset,
BA8 0PP

Tel: 01963 362484 Fax: 01963 364146
E: precisionclutch@aol.com
www.precisionclutch.co.uk

MORRIS MINOR OWNERS CLUB Dorset Branch

THE DMMOC MONTHLY MAGAZINE

PATRONS: *Their Majesties
The King and Queen*

33RD INTERNATIONAL
MOTOR
EXHIBITION
CARS BOATS & CARAVANS



OCT. 27 to NOV. 6 1948
EARLS COURT

OFFICIAL
CATALOGUE 2/6

1948



2023

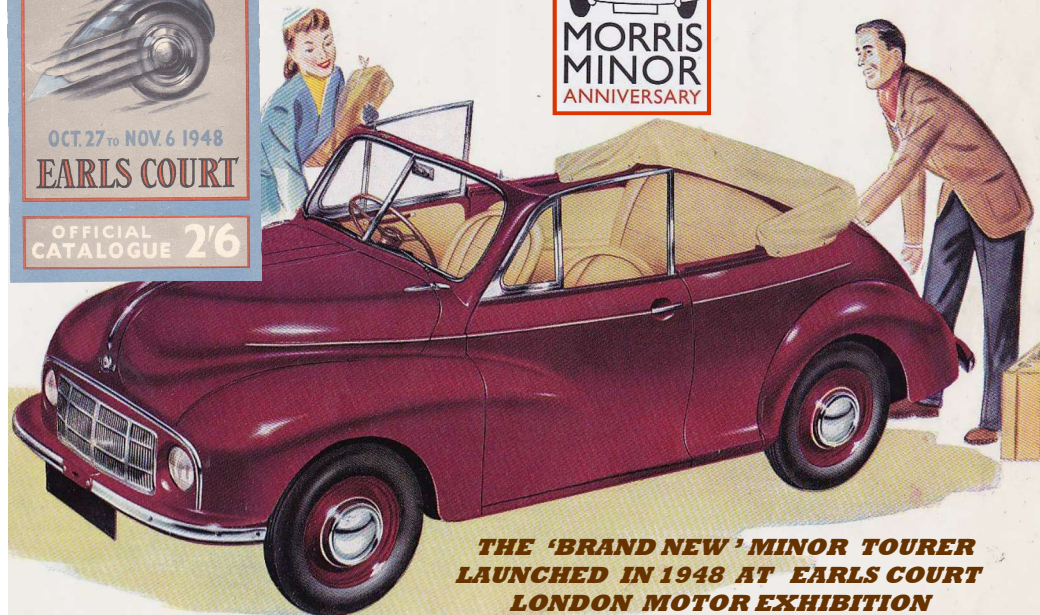

THE 'BRAND NEW' MINOR TOURER
LAUNCHED IN 1948 AT EARLS COURT
LONDON MOTOR EXHIBITION



MAY 2023
Vol 26 issue 5
www.dorsetmmoc.co.uk

The MMOC Dorset Branch

was founded in 1980 by Graham Melly and chaired in the early days by Aubrey Batt. It is a Branch of the National Morris Minor Owners Club but has its own accounts and organisation (see Constitution for further details) **We meet on the first Wednesday of every month (7:30 for 8:00)** at the **Bournemouth Electric Club, Broadway Lane, BH8 0AA**. We have an active calendar of events throughout the year – particularly in the Summer months when we attend many rallies and other

COMMITTEE		Dorset Branch MMOC Key Contacts	
Branch Chairman	Laurie Blewer laurie.blewer@dorsetmmoc.co.uk 01202 522673		Non Committee Voluntary Posts
Hon. President	John Jenkinson 01202 576690		Raffle Coordinators Chris Tilley & Margaret Pateman
Branch Secretary	Ian Chivers ian.chivers@dorsetmmoc.co.uk 07779581837		Insurance Consultant Dave Walker (to DMMOC branch)
Branch Treasurer	Jacky Wood 01202 573494		Garden Competition Sub Committee Marilyn Kellow Sue Cooper Martin Harris
Branch Membership Secretary	Brian Ford brian.ford@dorsetmmoc.co.uk 07502161535		
Spares Manager	Brian Wood brian.wood@dorsetmmoc.co.uk 07411 116336		
Website Editor	Roger Kellow roger.kellow@dorsetmmoc.co.uk 07845768120		
Branch Magazine Editor	Karon Brown sandkbrown@hotmail.co.uk		
Health & Safety Officer			
<p>*Print Deadline* to ensure inclusion for any item included within 2023 edition please</p> <p><u>MONDAY 22nd MAY</u></p>			

DORSET BRANCH MEMBERS ADVERTS

S/H PARTS , VEHICLES , ETC .FOR SALE or WANTED

Any paid up Dorset Branch club member can advertise HERE FREE

1952 (Series MM) 2 Door Saloon

This rare car (known for many years to branch members as being owned by the late owner)s offered for sale at £8000. being fully restored some few years ago : recent M.O.T. Also a very large quantity of SeriesMM spares available and would be subject to additional negotiation .

All enquiries to :- Mr Laurie Blewer, Tel 01202 522673, (acting for past owner)



1957 Minor 1000 Convertible, 1098.

Heritage cert. New M O T, always garaged . Owned for 12 years.

Many upgrades inc. New wiring ,recon gear-box, new clutch, Disc brakes, Rear springs Front shocks, Master cylinder etc etc

Reluctant sale by Club Member

01202 575077 £ 8500



Branch Member's Miscellaneous Adverts

New Flower Arranging Class Thursday afternoons 1p.m. to 3. 30 p.m.

At Howe Croft Community Centre ,Turnbull Lane (off Holloway Ave) BH119BG (Near The Range)

For further information contact :- **Irene 01202 578530 / email - reneboot1@yahoo.co.uk**

(recommended by Jackie Walker)

Professional / Commercial Products & Services

(For advertising rates, please contact The Secretary or The Editor)

WOLVERCROFT GARDEN CENTRE

Based on over 2 acres 'Wolvercroft World of Plants' has been providing high quality plants for over 20 years.

Open 7 days a week : With knowledgeable friendly staff, and a visit to the popular 'Sticky Bun Tea Rooms' completes an excellent place ,out in the country, to visit. Fordingbridge Road ,Alderholt. SP6 3BE 01425 652437 w.w.w.wolvercroft.com

Old Autos

Old, Interesting and Classic Cars in any condition

BOUGHT AND SOLD

Paul 07890 096907, Ken 07814 385781
old_auto@yahoo.co.uk

Open Friday and Saturday or by appointment

Unit 1 & Compound C
Parley Wood Business Park
Barrack Road, West Parley
Ferndown. Dorset BH22 8UB

DORSET BRANCH CLUB SPARES DEPT. PAGE

**NEW CLUB SPARES for your Minor are available through the Branch
at up to 10% discount (to Branch Members)
Call or email Brian Wood 07411 116336**

Sample prices on New Parts

Oil filter: paper: £3.74 screw-on: £3.15
Air filter: £5.40, NGK spark plugs
£2.07ea
Distributor Doctor Condenser £8.55
Lucas Contact points £2.70
Distributor cap (push in) £4.95
1098 Clutch kit (2-pce) High quality
reconditioned (Precision Clutch Com-
ponents) £89.10 exchange.
**Reconditioned cylinder heads and
crankshaft kits.**
*(All prices are member's discounted rates and are
subject to change without notice)*

Refurbished Stock

Fuel Pumps £54.00 exchange
HS2 Carburettors £150 exch.
Gearboxes:
803, 948 or 1098 (from) £375

Indicator Switch Covers

These are now available for single
(indicator/flash etc) or double (inc. wiper
switch on left) for £48.50 and £79.00 re-
spectively. They are supplied with full in-
structions and all parts except the
switches.
(See website 'Special Items' Page for more de-



3D Print Department Latest

The 3D printed mirrors for the later '1000'
models are now available and will be on
display at Beaulieu. The discounted
branch member price is £25 (£28 to
others).
I have also recently made some more ob-
scure bits like the socket for the mirror
stalk at the top of the windscreen, indica-
tor stalk bulb holder covers and the small
ferrule that connects the Series II wiper
motor to the rack .



THE DORSET BRANCH MORRIS MINOR OWNERS CLUB MONTHLY MAGAZINE



MAY 2023 Vol: 26 Issue 5

**MAY CLUBNIGHT
Phil's Antiques Road Show**

In This Months Issue...

REGULARS	SPECIAL FEATURES
THIS MONTHS EDITORIAL P,4	P6/7 The Old Days !
EDITORS 'IN BOX & 'NEWSLETTERS' PAGE ' P5	P12 /13
CHAIRMANS REPORT P.10	P16/17
SECRETARY'S REPORT P. 17	
FORTHCOMING EVENTS P8/9	P18/19/20/21 Roadworthiness ??? (The Editor attempts to define' it !)
THE 'BRIAN WOOD' REPORT P. 12/13	
CLUB SPARE PARTS & ACCESSORIES PAGE FOR SALE P. 22	
MEMBERS SPARE PARTS ,VEHICLES ,MISC FOR SALE or WANTED PAGE P.23	

Dorset Branch Members- It's Your Magazine - It's Your Club !

*** * The Editor encourages and welcomes any written contributions -
Particularly loaned (or emailed) photos please, of topical interest, from club
members suitable for inclusion in the monthly club newsletter .**

***Please submit , if possible ,any material or advertising matter, within 10 days prior to the next
monthly club night date . (*Inclusion within the next available published newsletter is subject to
space, as it approaches the next respective monthly publishing deadline.**

**The Dorset Branch MMOC will accept no liability in respect of goods or services provided by advertis-
ers : No recommendation is implied : Any views expressed or advice given within the newsletter is
offered in good faith and no liability is accepted by the Dorset branch or the MMOC for any conse-
quences arising from such material.**

Welcome to the May edition, now that spring has 'sprung'

With **Moggyfest** only a matter of days away at the time of writing this months intro , it's absolutely great to mention again that Beaulieu have (as always before) been exceptionally encouraging towards the Dorset Branch's **Moggyfest** event . This year we are in a super location just prior to where visitors enter the Spring Auto Jumble areas . . Our main central display marquee cannot be missed when heading towards the Spring Auto Jumble area main entrance gate and sited next door to Beaulieu's own Press Marquee . Those visiting with your Morris Minor over the weekend have lots of space on the lawns adjacent to our central 'Earls Court 1948 ' display themed large main marquee . (We have the use of the areas each side of the 'Avenue ' leading towards Abbey Ruins and Palace House) We do look forward to anyone fully entering into 'spirit of the event' over the special weekend in celebration the 75th anniversary of our favourite car the Morris Minor. Laurie and I cannot wait to see some examples of any 1948 - 50s era costumes appearing (yes ,in full 'Goodwood Revival' style if you wish.) ... **I am also now delighted to say that there is an added incentive to those considering coming 'dressed for the occasion' (in any way at , all reflecting the era) as our best 'dressed lady and gentleman 'competition has now attracted the attention and support of ADRIAN FLUX CLASSIC CAR INSURANCE Ltd who have kindly provided vouchers for the winning couple in this special category to spend on classic car insurance cover (with special thanks to NICK WILKINSON of Adrian Flux . Nick has incidentally just sponsored the PRACTICAL CLASSICS monthly magazine National 'Golden Spanner Award' for Restorer of the Year' having presented it last month at the Classic Car Restoration Show at the NEC**

We similarly also have another company to thank , as we have the kind support from **EAST SUSSEX MINORS (ESM Minor Spares)** who have kindly provided a voucher specially for the winner of 'Best in Show Car' at **Moggyfest** weekend to help he or she towards the purchase of **ESM Minor Spares**.

'**Road Worthiness**' - a statutory requirement for anyone to comply if using any vehicle on our roads and that of course includes any classic vehicle. In spite of not requiring to pay road tax as a Vehicle of Historic Interest class category (VHI) or legally requiring to submit the majority of classic vehicles annually for an MOT . Roadworthiness , in the eyes of the Vehicle Standards Agency , sets a required criteria for all vehicles to follow. So a very good place to look for reminders are the various categories that any qualified MOT Inspector has to follow whilst carrying out an MOT inspection. It is entirely your own decision at the end of the day whether you prefer to organise your own vehicle checking, or you wish to submit your vehicle 'voluntarily' for a once ,twice yearly, or whenever you choose for an MOT test. I must admit to being surprised at the number of areas, that (when I excluded 'modern car' items from the present MOT that would not apply to a Minor) there are in fact still many items that can easily be assumed to still apply to an older car. Please note in creating this article **Pages 18-21** I am not suggesting you do, or do not have an annual MOT It's your own decision. **(Please do let me know any of your own opinions ,either way ,**

on this particular subject , in order to share !!) , ROGER



(Cat 6) BODY STRUCTURE AND ATTACHMENTS General condition and/or excessive corrosion effecting the general structure of the vehicle, in particular to the load bearing 'prescribed areas' and in those also covered in other specific testable areas (i.e, the mounting areas of brakes, steering, suspension and seat belts. Condition of engine mounts , body panels, floor panels, structural body pillars . Passenger compartment must not allow exhaust fumes to enter through body structure. Doors catches and boot lid catches can be effectively secured . Bumpers are secure . There must be no sharp edges or projections caused by corrosion or damage . Seats—driver and passenger seats are checked for structural soundness and fixing security. Towing bracket (if fitted) Checked for security and condition of fixing points (identified as prescribed areas) Exterior rear view mirrors , security and condition.

Fuel system , Check fuel tank for any leaks including condition of filler neck tube, presence and security of filler cap. Check made on condition of fuel line hose or pipe s from under bonnet to the fuel tank.

(Cat 7) SEAT BELTS & AUDIBLE WARNING (Horn) SPEEDOMETER & Warning Lights (cars after 1965 have seat belts fitted) Inspection of anchorage points for structural soundness (prescribed areas)

Condition of seatbelt material and all mechanisms checked . Child seats checked that are permanently attached to the vehicle using nuts & bolts or Isofix attachment. A horn must be of an acceptable level and tone to be heard by other road users without being harsh or grating. It cannot be more than one tone or sound like a siren or sound likely to be confused with an emergency vehicle. The speedometer is checked for operation, condition, and night illumination . 'Tell Tale lights (i.e. Headlamp main beam & direction indicators) are checked for operation

(Cat 8) NUISANCE (Exhaust /Emissions /Noise /Fluid Leaks The exhaust system is checked for condition & effectiveness ,any leakage and the condition of attachments . Exhaust noise is assessed and is not 'unreasonably' above the average estimated noise level expected from a similar vehicle model fitted with a standard silencer, in average condition, when revving at around 2,500 rpm together with assessment of the level state of exhaust emission (smoke) subject to emission test exception on some age related vehicles

(i.e. Pre Aug 1975) A fluid leak deemed harmful to the environment or to other road users should not be capable of creating a pool of liquid within 5 minutes that is more than 75mm diameter .

(The Editor does not claim this is a fully complete and comprehensive list and has excluded certain 'modern car' items listed that would not apply to 40 plus year old cars . All above details have been sourced from the latest available Driver & Vehicle Standards Agency published information referring to 9 Mot test listed catagories - In presenting this article the Intention is essentially to present it as a 'discussion document ')



(Cat 2) STEERING GEAR Security of steering rack ,any play in steering joints , inspection of any other swivel joints, condition of rack gaiters, wheels not fouling any items when fully locked from side to side , checking any lock nuts or retaining devices Steering checked when car jacked including wheel bearing check . Steering column security and checking for excessive steering wheel 'free play' .

(Cat 3) VISIBILITY Items affecting the driver's view of the road and the condition of the windscreen - Operation and effectiveness with the condition of wipers and sufficient washer fluid being effective to clear the area of drivers vision. Check security and condition of the Bonnet Catch (now included in 'Visibility' due to a bonnet 'flying up' would obscure the drivers view)

(Cat 4). LIGHTNG & ELECTRICS Headlights checked for—Aim ,dipped beam aim and condition Side lights , operation and condition Stop lamps for presence, operation and condition. Direction indicators and hazard warning lamps for presence, condition and operation of flashing frequency. Rear registration plate s Rear reflectors condition . General Condition of wiring and fixing security of the Battery. Condition of towing bracket wiring and operation. (if fitted)

(Cat 5)TYRES , WHEELS , SUSPENSION & AXLES Condition of Tyres and fitting check for any damage on outer and inner sidewalls . Tread depth across entire band . No mixed structure type on same axles (cross ply / radial) Condition of road wheels and rims . Wheel nuts all present . Condition of Wheel Bearings tested when car jacked , for excessive play when rocked testing for roughness or noise when a wheel turned . All mechanical joints, levers, springs and other items associated with the vehicles suspension checked for cracks ,breaks, excessive corrosion , together with the condition of the vehicles load bearing structure to within the prescribed distance to which the suspension item is attached (i.e 30cm) . Checked for play in upper and lower joints and also with other associated components . Axles are checked for security of attachment . Shock absorbers checked for attachment security, wear or deterioration and effectiveness , also checked for any excessive leaking of fluid.



FAREWELL TO MIKE

We gathered at Poole Crematorium on Thursday 13th April, a lovely spring day, and joined with Mike's family in wishing a 'Very Fond Farewell' to our friend and long serving Dorset Branch member **MIKE SHEPPARD**



THE CLASSIC OWNER'S VOICE AT WESTMINSTER' Re-Elected

The Editor apologises for featuring politicians at this particular time when they are constantly hogging the headlines ! But.. Jensen-owning (and Allard shown below) MP SIR GREG KNIGHT has been re-elected (unopposed) as Chair of the All-Party Parliamentary Historic Vehicle Group at Westminster.

The Group was founded by East Yorkshire Conservative MP Sir Greg and the late Labour MP Bob Cryer to offer support to historic vehicle owners and promote the continued use and enjoyment of classic vehicles The group works closely with the Federation of British Historic Vehicle Clubs (FBHC) and the incumbent Transport Minister at the time to lobby government over legislation affecting our continued freedom of use for classic cars on British roads . Ed



DEAR EDITOR— RE 'CUBNIGHT DESERTERS' Here's a "Splinter Group" drying out at The Angel in Ferndown on Wednesday after the April Clubnight "lock out affair" !!!

It looks like Mike & his good lady do not seem that impressed with the alternative to the usual sandwiches !!!!! Hey ho... worse things are happening in the world. Best wishes from Peter Houghton (& Dee)



**HERE'S TO THOSE 'GOOD OLD DAYS' ... of the late 40' & early 50's *
SEE YOU AT MOGGYFEST Beaulieu !**



THE DRIVER & VEHICLE STANDARDS AGENCY USE THE FOLLOWING CRITERIA FOR DETERMINING WHEN A VEHICLE IS DEEMED 'ROADWORTHY'

When carrying out an MoT the tester is required to logically work through the following areas, it's down to the tester, the order they choose to do it, but they are required to cover all the listed areas during the course of a test. If a tester discovers any 'Defect' within the prescribed area listings it has to be noted as one of three 'Defect' Categories ..

- 1. 'MINOR' Defect, means the item identified has not failed the MoT, but is a defect which should be fixed as soon as possible and an 'Advisory' entry will be noted onto the MoT certificate for the drivers attention.*
- 2.. 'MAJOR' Defect means an 'MoT Fail' and the the item will need to fixed in order for the vehicle to 'Pass' (the vehicle can be driven to and from the test location only it is required to be taken directly to another specialist for re-quired work to be carried out if it is safe to do so)*
- 3. DANGEROUS defect means an 'MoT Fail' where the vehicle should not be driven on the road until the required work is carried out before a re-test.*

The present D&VSA categories are grouped in the areas as follows :-

(Cat. 0) VEHICLE IDENTIFICATION (VIN No & Registration plates (May be white, grey or silver characters on a black background for vehicle constructed pre Jan 1978) Must have correct size and pattern of font characters . Must be clearly visible and not deteriorated.

(Cat.1) BRAKES Efficiency and Balance. Footbrake pedal travel. Pedal anti slip . Condition of flexible & metal pipes . Any signs of brake fluid leaks— involving checking the key areas of the system . Parking brake checked for effectiveness , condition of linkages and amount of ratchet travel. Braking effort is adequate on each wheel and the braking effort is adequately 'in balance' for wheels sharing the same axle (The vehicle does not deviate to one side excessively from a straight line when brakes are applied) Brakes on any wheel are ineffective due to an excessive degree of brake binding when wheel turned.

Cont

WHAT DEFINES BEING 'ROADWORTHY' ?

The Driver & Vehicle Standards Agency have a comprehensive list that specifically highlights the areas used for determining whether a car is deemed to be 'Roadworthy' or 'Not Roadworthy' during the process of a Ministry of Transport Test (Mot). This of course includes any classic car. Whether a classic car is voluntarily presented for an Mot or not it's the responsibility of the owner/driver to keep the vehicle in a 'Roadworthy Condition' when used on any UK roads.

Since May 20, 2018, the cut-off for MoT test exemption has been based on a rolling 40-year vehicle age, meaning that most vehicles built or registered at least 40 years ago, and qualifying for Vehicle of Historic Interest (VHI) status, no longer requires an annual MoT test. However there are many differing views within the classic car industry and amongst owners - Some will say ... "I always voluntarily have an annual Mo t test for peace of mind with the added thought that it is being systematically looked over by another persons eyes -. There are some that suggest the French system of 'Contro'le Technique' (CT) should be considered in the UK where modern private cars are tested every two years (commercial vehicles still tested annually) You could argue that the French may possibly have a wise 'compromise' for French owners of classic cars over 30 years old designated as a 'Ve'hicule de Collection' being used in France requires a 'roadworthy' test every 5 years .All vehicles that pass (whether the 2 year or 5 year requirement applies) also have to display a stamped sticker (vignette) on the windscreen showing when the next (CT) test is due . On the other hand some who have a practical knowledge of the areas that come within the MoT testers remit and checklists say "I always do my own servicing and I am confident to have sufficient knowledge to recognise and regularly make sure my car is maintained mechanically, electrically and structurally" then others may say "I have a very knowledgeable person I fully trust who inspects my car at set times and would carries out any mechanical work and advise on structural work that may be necessary , also it is serviced by another person who is fully familiar with everything mechanical including the checking over the correct performance of brakes , steering , clutch etc.



The advert said it only needed a few 'minor' jobs !



**Was life more difficult then ? Or was life happier then and less stressed ?*

Just a few examples of 'life then' in the late '40s & early 50's

No mobile phones. No personal computers . No 'social' media. No daytime TV. Steam railways. We had a British car industry and British cars. Towns had high street banks . There were park keepers in parks . Your doctor would visit at home and know your name . Conductors on buses. 'Local' Pubs in every village .



FORTHCOMING EVENTS & ACTIVITIES

Dorset Branch MMOC organised Events are headed thus.. DORSET MMOC

MAY 1st	South Coast Classics (at South Coast Karting Centre (Circuit) (CCOTP event) 11 a.m —4 p.m—times can be checked on CCOTP F/b page (and also the latest information on dates/times for new evening events)
MAY 1st	Popham Air Field Classic Car Show 10.am—4pm For booking availability contact organisers— www.evenbrite.co.uk (Popham , Hants)
MAY 3rd	DORSET MMOC MAY CLUBNIGHT Antiques Evening with PHIL TRAVES (bring your favourite antique or collectable for expert Phil to appraise)
6th/7th MAY	Breamore House Steam Working Weekend—To attend this event now requires individual booking— rustyspanner@icloud.com or 07790354505
MAY 8th	South Coast Classics (at South Coast Karting Centre (Circuit) (CCOTP event) Details & Times —see May 1st above
MAY w/end of 13th /14th	<div style="display: flex; justify-content: space-between; align-items: center;"> <div style="text-align: center;"> <p>DORSET MMOC MOGGYFEST 2023 (The 75th Minor Anniversary Event) at BEAULIEU (Incorporating Nat: MMOC Southern Regional Rally) Admission now available through the visitor ticket for entrance to Spring Auto Jumble (pay on entry, direct to Beaulieu)</p> </div> <div style="text-align: center;">  </div> </div>
MAY 21st	Freinds of Victoria Education Centre (a registered charity) VICTORIA CAR SHOW Craft & Vintage Day 10 a.m—4 p.m. 12 Lindsay Road Poole BH13 6AS www.victoria.poole.sch.uk (Please let Laurie know if going as we probably will form a group display)
JUNE 7th	DORSET MMOC JUNE CLUBNIGHT 'When You Were a Baby' (Guess Who's Who - Please submit your old baby photos to Laurie In good time * ideally bring them on MAY clubnight
JUNE 17th/18th	Moors Valley Steam Summer Gala W/End (Booking direct to M.V.R by 21st April- for all details visit - www.moorsvalleyrialway.co.uk
1st/2nd JULY	The National Morris Minor Owners Club Annual Rally Chateau Impney, Droitwich, Worc WR9 OBN Bookings- www.mmoc.org
JULY 1st	Burton Scout Carnival , Burton Recreation Field. Whilst there is no need to book for this event cars always need to arrive before 11a.m. as access roads through village are closed for the Carnival procession to arrive. (Further details to follow from branch member BRIAN TILLY)



DORSET MMOC Secretary's Report

It's just over a week to go before one of the main events of the year, Moggyfest, which is also the National Southern Regional Rally. This takes an incredible amount of planning and hard work to put on, more than our own branch rally. I hope that you all enjoy the weekend, I look forward to seeing you there for what promises to be a fabulous show. I'll be 'working' in the spares department, so please stop by and say hello .

Apologies for the April club night, for those of you who weren't there we were locked out of the Southern Electric Club. Some members took cover from the rain in the smoking shelter (photo) while Laurie tried in vain to contact the staff. I understand there have been some changes in the running of the club, which only opens especially for us on the 1st Wednesday of the month. Laurie eventually received a grovelling apology, apparently our meeting wasn't in the calendar! We've been assured that the next (this) meeting will be hassle free, which is the antiques evening. So far, we haven't had many of your baby photos for the June club night, we really need these now if the planned evening can go ahead. You can take a photo of the photo and email it to Laurie, if we don't get enough entries, we may change it to hobbies.



Laurie recently attended a show at Spetisbury called 'Vintage crank up at the Shack'. The Shack is a bar/café on a farm and could accommodate us for a breakfast meet up. After breakfast I could be tempted to drive the extra 10 minutes up the road and visit the Badger Brewery shop in Blandford .

Several members have commented on the state of my driver's door latch, mainly that it's broken and should be replaced. However, it still worked ok if I slammed the door hard enough! I suppose it was only a matter of time before the inevitable failure of the latch, it eventually gave up the day before the Swanage Charity day. Luckily, I was less than ½ mile away from the spares department when it broke. I managed to drive there holding the door shut by the strap, a bit of angle grinder fettling later, and the door shuts better than it has ever did since I had a new rubber door seal fitted. I must remember that I no longer need to slam it shut. The passenger side is also broken and difficult to close, so I'll be fixing that before it breaks.

Finally ,this year's MOT (Minors On Tour) UK is coming to Dorset, so we've arranged to meet up with them at the Northe Fort in Weymouth on Friday 21st July. We've arranged special permission to park up inside the fort itself which should be quite a spectacle (Photo opportunity!), as such cars will need to be there before 10:30. The cost will be £4 per person or £5 including a tour.

IAN

Traditionally, an ammeter would have been used in conjunction with a dynamo charging system but there is nothing wrong with using a voltmeter, although its 'on charge' reading will be slightly lower than with an alternator, typically 13-14 volts. The two-wire output found on most aftermarket alternators creates a problem fitting an ammeter; a voltmeter is a much easier alternative. Unlike an ammeter, a voltmeter does not indicate the amount of current going in or out of the battery. Instead it samples the voltage of the system and offers the suggestion that if the reading is within satisfactory limits, all is well. Both types of meter have good and bad points, neither can give total assurance that your electrical system is perfect, but they will alert the user to fundamental problems. Wiring up a voltmeter is extremely simple, as there are only two wires and they don't need to be of heavy gauge because a voltmeter merely takes a sample, unlike ammeters which have the entire current passing through them. It doesn't matter which way round a Smiths meter is connected, but some makes of meter are fussy about polarity, terminals are marked + and - in the usual fashion. If your car is negative earth, connect the negative terminal of the meter to a good earth point. For positive earth cars, the positive terminal should be earthed. The remaining terminal must be connected to any convenient 'live' source which is controlled by the ignition switch. The fuse box is as good a place as any; on a Minor, connect to the same terminal as the white coloured wires. Connecting the meter to a permanently live source is not recommended as it will be in circuit all the time regardless of the ignition switch and will slowly drain the battery when the car is not being driven.

There should also be a provision for internal illumination of the gauge and the wire from the bulb holder must be connected to the panel lamp circuit behind the dash. The casing of the meter may need to be earthed. It is always important to make good electrical connections, soldering terminals on, insulating where necessary and keeping wiring neat and tidy.



Rear of the original Smiths ammeter

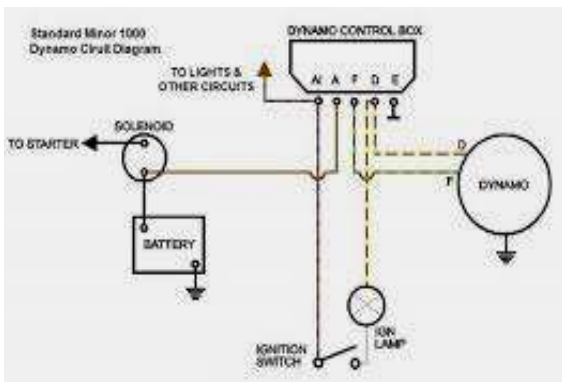

Rear of a 'new spares' voltmeter



JULY 5th	DORSET MMOC JULY CLUBNIGHT *Meet at 'The Den' * Antiques , Secondhand Curios & Coleectables Centre at Wallisdown *MEET at THE DEN, Francis Ave BH11 8NX <u>NOT at the Electric Club</u>
JULY 15th	Holdenhurst Village Fete To assist organising parking space it would helpful to inform Laurie if intending to attend this event
JULY 21st (Friday)	DORSET MMOC Special ROAD RUN to Nothe Fort Historic Site DT48UF , WEYMOUTH , meeting up with the Annual' Minors On Tour 2023 ' group .(Aiming to arrive at Nothe Fort Weymouth at 10.30) Subject to space Minors are invited to park in the Fort central courtyard. Admission and Guided tour of site at substantially reduced rate of £5 on the day (or £4 without guided tour)
JULY 31st	DORSET MMOC Summer Garden Party at Lauries (Details to follow)
AUG 2nd	DORSET MMOC AUGUST CLUBNIGHT (Subject Provisional—TBC) DMMOC Founder Graham Melly - 'Earlier Days of the Dorset Branch ' (including the screening of Graham's selected original archive cine films of some Dorset branch club events in the early 1980's) MEET AT UPTON HOUSE CAR PARK AT 9 a.m. - (please advise Laurie if intending to participate in the run)
AUG 19th/20th	DORSET MMOC - THE DORSET BRANCH ANNUAL RALLY at Wolvercroft World of Plants Rally Site , ALDERHOLT Nr Fordingbridge (booking forms to follow & camping is available on site from the Fri p.m.) Booking forms available soon
AUG 28th	South Coast Klassics (at South Coast Karting Centre <u>Circuit</u>) (CCOTP event)
SEPT 2nd/3rd	Beaulieu International Autojumble—entry by ticket direct from Beaulieu (Dorset Branch exhibit at Moggyfest/ Spring Autojumble May 13/14th)
SEPT 6th	DORSET MMOC SEPT CLUBNIGHT Annual Gardening Competition
SEPT 24th	Simply British Classics at Beaulieu—Entry online direct from Beaulieu , but please advise Laurie if attending (as we normally arrive in a group 'convoy run ' with a Dorset branch club group parking area booked) www.beaulieu.co.uk/events
OCT 4th	DORSET MMOC OCT CLUBNIGHT 2023 Annual General Meeting
NOV	DORSET MMOC NOV CLUBNIGHT (Subject TBC)
DEC	DORSET MMOC DEC CLUBNIGHT Seasonal 'Noggin 'N Natter '

DORSET MMOC Chairman's Report

Hello everyone and welcome to the May edition of the newsletter. Firstly, can I apologise for the mess up with our April clubnight. When we all arrived the hall was locked up and in darkness and nobody from the club turned up at all. I have since been told that our meeting wasn't in their diary! Least said about that the better but I have since received a grovelling apology and an assurance that it will never happen again. So, all things being well, we will be in the hall tonight for the ever popular antiques roadshow evening presented by Phil. Hopefully you've all brought along a good selection of things for him to look at and tell us about.



Don't forget that the June clubnight is supposed to be a baby photo competition. Unfortunately, I haven't had many photos given to me yet so if we want to do this I will need your photos ASAP in order for me to prepare the competition. On Easter Sunday we took a run out to Clapcotts Farm in Spetisbury where they were holding a vintage vehicle and steam meet. There was a brilliant turn out of vehicles of all ages, plenty of steam traction engines and an enormous number of vintage tractors which turned up after they had been on a road run. The farm itself is very nice with a tea rooms and a bar along with a small farm shop. I have made enquiries about us having a breakfast meet there are they are very keen to help.

I mentioned last month that we were planning on meeting up with The MOT UK group who are holidaying in Dorset this year. I have arranged for us all to meet up at Nothe Fort in Weymouth on FRIDAY 21st July. We will be leaving from Upton Country Park at 9am and aiming to arrive at Nothe Fort before they open to the public at 10:30. We will be parked up inside the walls of the fort and the entry fee will only be £4 per person or £5 if you would like a guided tour. There is a booking form with this newsletter.

We are only a few days away from our big event of the year, Moggyfest 2023 at Beaulieu. All the planning is done now so it's all systems go. You should have received your passes etc either in the post or tonight. As usual if any of you would like to help with the marshalling you will be only to welcome as your committee can't do everything!

Thank you to everyone who came along to pay their last respects to our good friend Mike Sheppard. A lovely line up of Minors greeted him at the crematorium to say their good byes. Mike was a lovely guy and we'll all miss him at clubnights and club events and our thoughts go out to Joyce. Rest in peace Mike.



Original Smiths Ammeter

***Editors saloon 'D.I.Y.' glove box panel
Smiths Water temp - Ammeter - Oil pressure***



Favourite locations, which will not disfigure your car irreversibly are below the dash on separate brackets or on a panel, usually of wood (example above) fitted into the driver's glovebox aperture, thus gaining extra mounting space but preventing its normal use. With a wooden panel you are on your own when it comes to manufacture. There are fibreglass replacement glove box doors with three 2" holes for gauges which are available via the internet. Metal underdash brackets are easily available and can accommodate one, two or three gauges. They are not too difficult to make at home, but remember to cut the large hole(s) first! All auxiliary gauges will require either extra wiring or tubing which passes through the bulkhead. Care must be taken here to avoid chafing; the main wiring harness grommet can usually accommodate these. For ease of assembly at the factory the grommet and its clamping plates are split, removal of the three self-tapping screws will release the assembly and give access. The voltmeter, (below) also known as a 'battery condition indicator' is a simple instrument which measures the voltage, or 'potential difference' across the battery. With the vehicle 'at rest' it is the voltage of the battery alone which is indicated; a decent one will show 12-13 volts. With the engine running there should be a slight rise in the reading, 13-15 volts on an alternator-equipped vehicle, owing to the charging system coming into play.

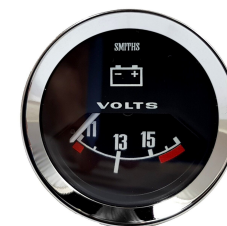

Voltmeter

FITTING SUPPLEMENTARY GAUGES IN THE MINOR

PART 1 - AMMETERS & VOLTMETERS

We delve into the 'Technical' archive resources of the Dorset Branch as originally written by our special Technical Correspondent 'RB'

“We All Run On Two Clocks “ ... is a theory propounded by Max Lerner, in the introduction to his hypothesis concerning the human 'body clock'. Ever since their introduction car speedometers and other gauges have been, with a few exceptions, erroneously nick-named 'clocks'. Here, we will look at a few auxiliary gauges or 'clocks', and their fitting. Before taking Mr. Lerner's ideas on metabolism too seriously we must remember that he was not a physician but a journalist.



In keeping with his notion however, the standard (post series MM) Morris Minor was a "two clock" layout comprising a speedometer and a petrol gauge; rather basic perhaps but cost-cutting was just as important then as now. A little further up the price range, most family saloons had a little more instrumentation on their dashboards; always a fuel gauge plus any combination of oil pressure gauge, temperature gauge, ammeter and timepiece. Such gauges, if working properly, are of much

practical value and a certain source of comfort, particularly on vehicles which are used for long journeys and here it is proposed to discuss the fitting of these. Perhaps the most useful is a temperature gauge followed by voltmeter/ammeter and oil pressure gauge. A timepiece is well - worth preserving if an original fitting, otherwise can be considered superfluous in these days of electronic watches, mobile phones etc. The manifold vacuum gauge can reveal much about an engine and its driver but is an acquired taste which does not appeal to all. The best-known and commonest make of gauge is Smiths, and it is the only make for anyone hoping to compile a matching set. The Smiths Instrument Company has moved into higher technology but at the time of writing Caerbont Automotive Instruments Ltd. in South Wales makes identical products which, with the blessing of Smith's, carry that firm's name (below). Second-hand gauges of various makes are available, Ebay usually having quite a few on offer at all times. It is of course vital to ensure that used items are in working condition, some types being easier to test than others. Voltage indicators are often inaccurate and temperature gauges with electrical sensors are the least likely to give a correct reading unless some careful component matching is achieved. Unfortunately, the Minor's dashboard arrangement does not leave a great amount of scope for the fitting of extra gauges without doing permanent damage.

Voltmeter



As I write this we have just returned from our Drive It Day Run to The Swanage Carnival Classic Motor Show. (photos below) A selection of cars met up at Upton Country Park for the run to Swanage where we were all parked up together. There was a good turnout of vehicles despite the not so favourable weather forecast which in the end turned out OK until it was time to go home. A good day out which next year is on Sunday 21st April.

I think that's about all from me for this time, so until Moggifest, Happy Minoring, Laurie.



THE 'BRIAN WOOD' REPORT

**(& Latest News from
the Spares Dept.)**

Some of you may know that we are planning to go to France for the early May bank holiday with a few of the other Branch Members in our Minors. It is a bit of a 'leap into the unknown' for us as we have only been out of Dorset in the Convertible Minor a single time, let alone, abroad. Consequently, I have been prompted by this to get my act together and sort out all the 'snagging' issues on the convertible. This has taken several months (on and off!) and is now what could be regarded as being 'practically complete'. One of the items outstanding was the headlight adjustment. Whilst I have never been anywhere in the car after the hours of darkness, I felt that this should be corrected as a matter of safety and responsible ownership. Being fairly self-sufficient in the mechanical department, I have taken advantage of the MOT test exemption provision for classic cars and have not submitted my Minors for MOT since the concession was granted. We don't normally do excessive mileages in them, the Traveller has only done about 500 miles in the last 3 years. As you may know, there is a MOT style servicing/safety checklist on our Branch website (www.dorsetmmoc.co.uk/wordpress/tech_articles/servicesheet1.pdf).



The lack of requirement for MOT can be seen as a concession, so you can save £50 per year and let your car fall to bits around you! The other way of looking at it that it is a transfer of responsibility for the safety of the vehicle from the Government to the individual. This corresponds with a general trend in other areas of life where responsibility for one's action increasingly rests with the individual at the end of the chain (ie you and me) and inevitably boosts the workload of the legal profession. So, to box that off, the onus is on the driver (not necessarily even the owner) to be able to demonstrate that the car is roadworthy and not falling to bits. If, heaven forbid, one was to have an accident – say caused by brake failure, the inevitable question to be asked is 'when were the brakes last checked?'

If you have an MOT – whilst the tester may have completely missed the impending brake issue, you are able to prove that you have been responsible and taken steps to ensure that the car is safe. Self-checking is perfectly acceptable but you need to be able to prove that some attempt at checks has been carried out. Hence the service record sheet mentioned above. Being mechanically minded, I am fairly happy to do my own servicing and maintenance, but, of course, not everyone else is so inclined. That is when an independent test is a good idea.

Meanwhile back at the MOT bay in 'U-drive' in Poole, I prevailed upon the tester's good nature with a screwdriver on each headlight in turn – adjusting up a bit, left a bit, OK with the beam tester. He was very helpful with that. The rest of the test went well. There was a little bit of imbalance in the rear brakes, but the servo assisted discs on the front managed to make the car lurch out of the rollers. The tester was most intrigued. "Never seen a Morris Minor do that before!" he said !